

SP-TTL

Speed Sensor

Magnetic speed pickup with conditioned output

Up to

- 2,000 Hertz

Output

- 0 - 5 volt square wave

The SP-TTL speed sensor is capable of detecting passing ferrous objects including a gear tooth to enable shaft speed to be calculated.

The unit conditions the signal to provide a 0 - 5 volt square wave output. This enables it to be connected direct to panel meters or the Webtec C2000. It is all housed in a robust housing and comes complete with lock nuts for easy mounting and adjustment.

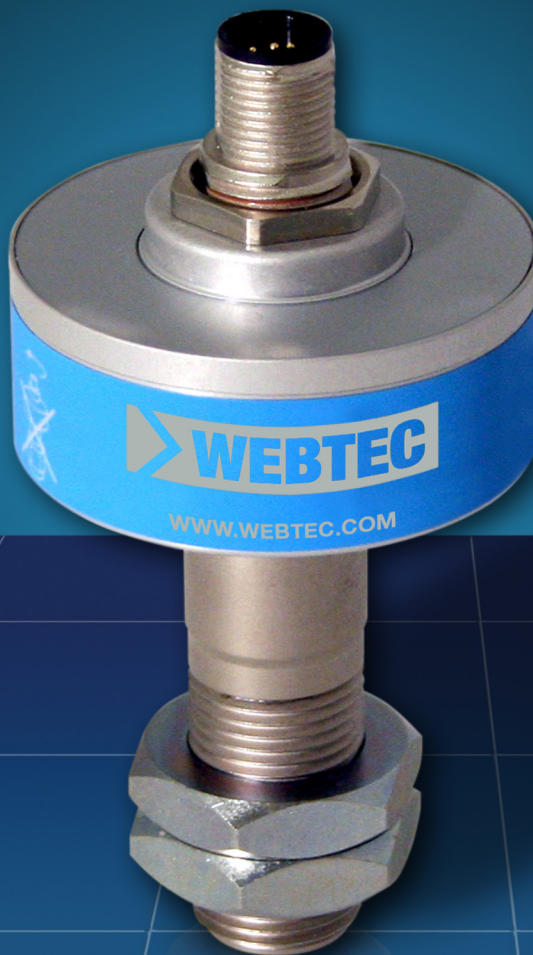

Milwaukee, WI 53235, USA

Tel: +1 (414) 769-6400
sales-us@webtec.com

St. Ives, Cambs. PE27 3LZ, UK

Tel: +44 (0) 1480 397 400
sales-uk@webtec.com

www.webtec.com

Features

- Wide range 1 - 2000 Hertz
- Steel and aluminium housing
- 0 - 5 volt square wave output
- Two lock nuts provide
- M12 5 pin connection



Specifications

Model number	Output	Frequency range
SP-TTL	Pulse	1 - 2000 Hertz

Functional specification

Operating temperature: Ambient - 5 to 40°C (41 to 104°F)

Weight: 0.25kg (0.55 lbs)

Electrical specification

Supply voltage (VS): 12 - 32 VDC

Pulse output: 0 - 5 V square wave, minimum load 600 ohms

Connection type: M12 x 1 5 pin

Construction material

Main Body -steel 212A42 electroless nickel plated,

Lid - Aluminium 2011 T3

Treaded section - 212A42 electroless nickel plated

Installation and connection details

Dimensions in mm (inches)

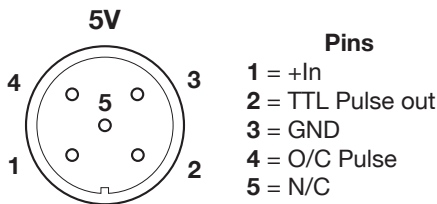

NB. N/C - Do not connect

Connecting cable (5m) FT10228-05

Extension cable (5m) FT10229-05

Connector (M12x1 5 pin) FT9880

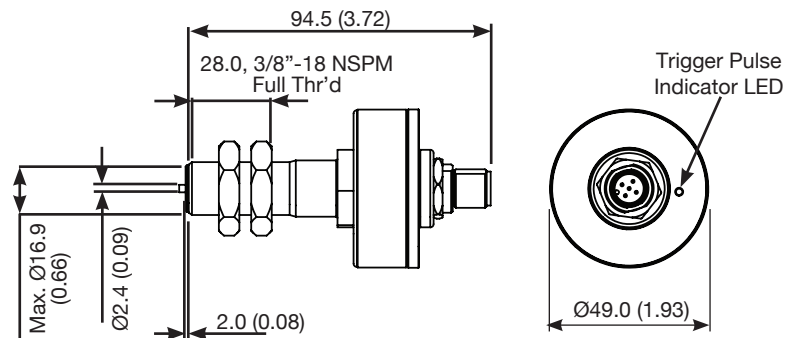

Installation guidance

When using the sensor to detect a gear tooth, there is an optimum shape to achieve maximum output voltage from the sensor before conditioning. This relationship is as follows:

A is equal to or greater than 2.3mm

B is equal to or greater than C

C is equal to or greater than 7mm

D is as close as possible

E is equal to or greater than 2.3mm

The above configuration is usually not available in a stock gear, but it is not necessary to have the maximum output into the conditioning. Conventional stock gears can be used if the tooth width A is equal to or greater than 2.3mm and C is 3.5mm.

For ease of alignment, it is recommended that the gear thickness should be at least 5mm.

When using the sensor to detect a bolt head or other ferrous object, as a 'detecting head' the following should be considered:

Use only solid material - filled cap head bolts can give a double count

Keeping the detecting head thin between 1.5 and 2mm will give the greatest speed range

The maximum velocity of the detecting head should not exceed 25 m/s

Ensure the detecting head provides the only edges within 10mm of the sensor

Magnetic Sensor

A = Dimension of top of tooth

B = Height of tooth

C = Space between teeth

D = Clearance

E = Gear thickness

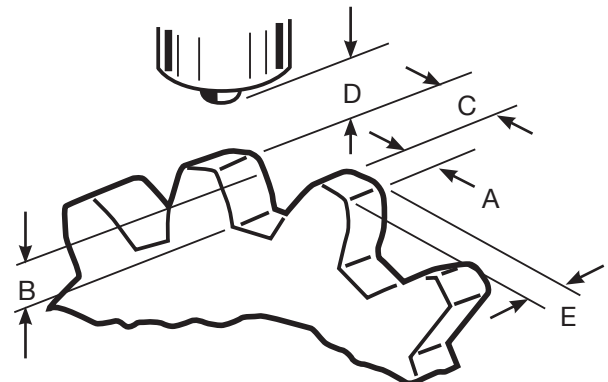

Accessories

A range of panel meters are available please contact the sales office for help and advice on your application.