

The BMH series advanced **ROLORTORC™** gear set, shaft distribution flow, hydraulic motor is a compact, low noise, high efficient high torque low speed design. The **ROLORTORC™** gear set also affords a reliable smooth start up at low pressure.

The special design of the valve linkage and high pressure capability of the shaft seal provides a long operating life and these motors can be used in either series or parallel operation.

The low weight advanced construction design is manufactured in accordance with the requirements of ISO 9000-2000 quality system.

Technical Specifications - BMH

MODEL		BMH-200	BMH-250	BMH-315	BMH-400	BMH-500
Displacement	CM ³ /Rev	203.20	255.90	316.10	406.40	489.20
	(In ³ /Rev)	(12.40)	(15.62)	(19.30)	(24.80)	(29.90)
Maximum Speed RPM	Cont	366	290	236	183	155
	Int.	439	348	282	220	166
Max Torque NM / (in.lbs)	Cont	510 (4513)	621 (5496)	740 (6549)	864 (7646)	799 (7071)
	Int.	579 (5125)	702 (6213)	827 (7319)	988 (8744)	971 (8593)
Max Differential Mpa / (PSI)	Cont	17.5 (2580)	17.5 (2580)	17.5 (2580)	15.5 (2285)	12.5 (1845)
	Int.	20 (2950)	20 (2950)	20 (2950)	19 (2805)	16 (2360)
Max Flow L/min / (gpm)	Cont	75 (19.75)	75 (19.75)	75 (19.75)	75 (19.75)	75 (19.75)
	Int.	90 (23.7)	90 (23.7)	90 (23.7)	90 (23.7)	90 (23.7)
Weight Kg / (lbs)		10.5 (23.10)	11 (24.20)	11.50 (25.30)	12.30 (27.10)	13 (28.60)

Continuous = maximum of continuous operation

Intermittent = maximum operating range for 6 seconds per minute

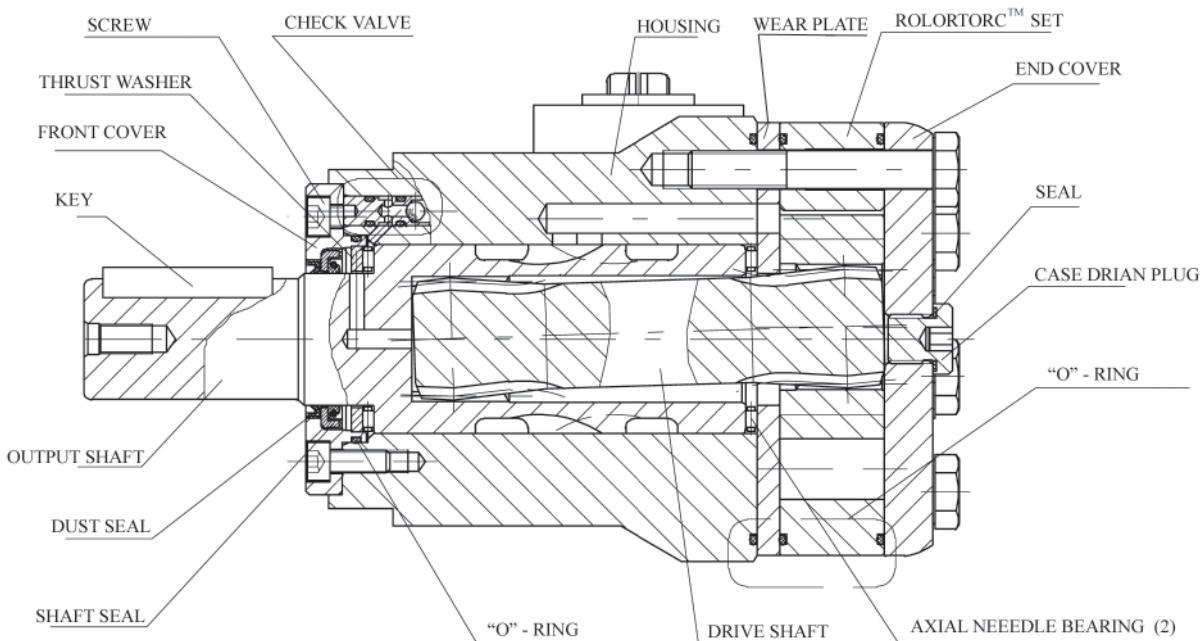

BMH INSTALLATION DATA

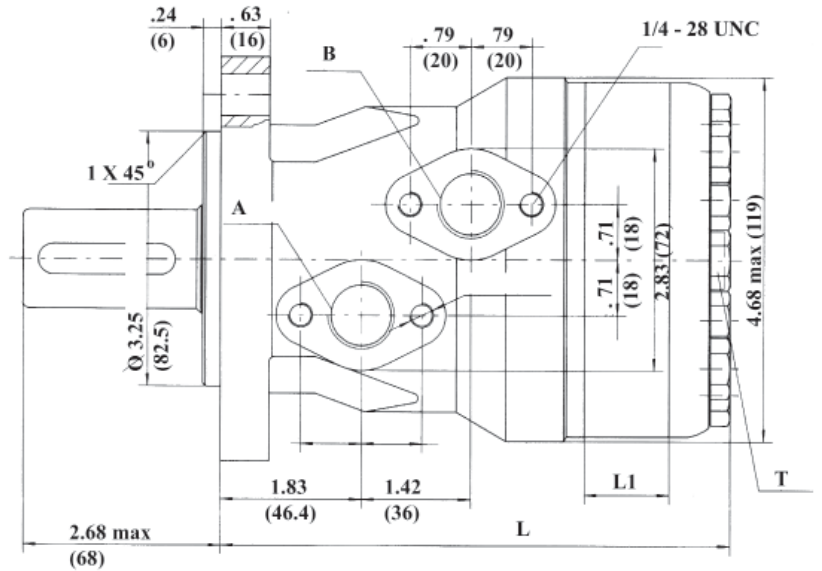
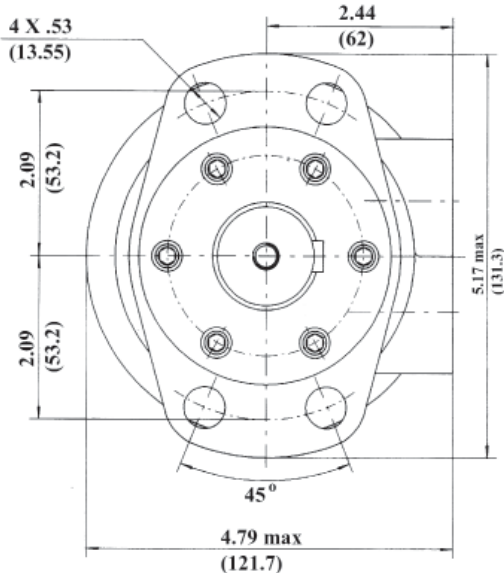

MODEL BMH	L		L1	
	inches	mm	inches	mm
BMH 200	6.61	168	1.06	27
BMH 250	6.89	175	1.34	34
BMH 315	7.24	184	1.65	42
BMH 400	7.68	195	2.12	54
BMH 500	8.11	206	2.56	65

PORT SIZES	SAE	NPT
P (A,B)	7/8-14 SAE	1/2-14 NPTF
T	7/16-20 SAE	7/16-20 SAE

MODEL BMH DRIVE SHAFT DATA

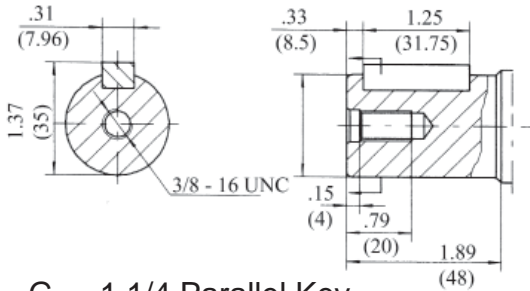

G - 1 1/4 Parallel Key

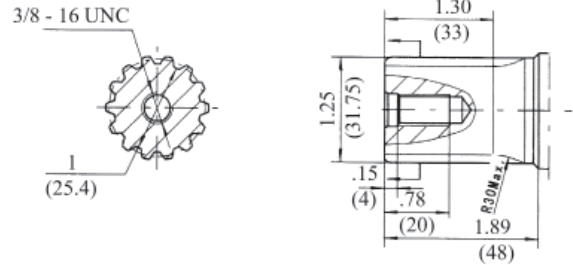

F - 1 1/4-14 DP Spline

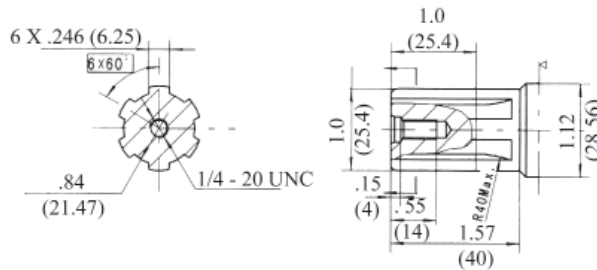

S - SAE 6B Spline

BMH MODEL NUMBER DATA

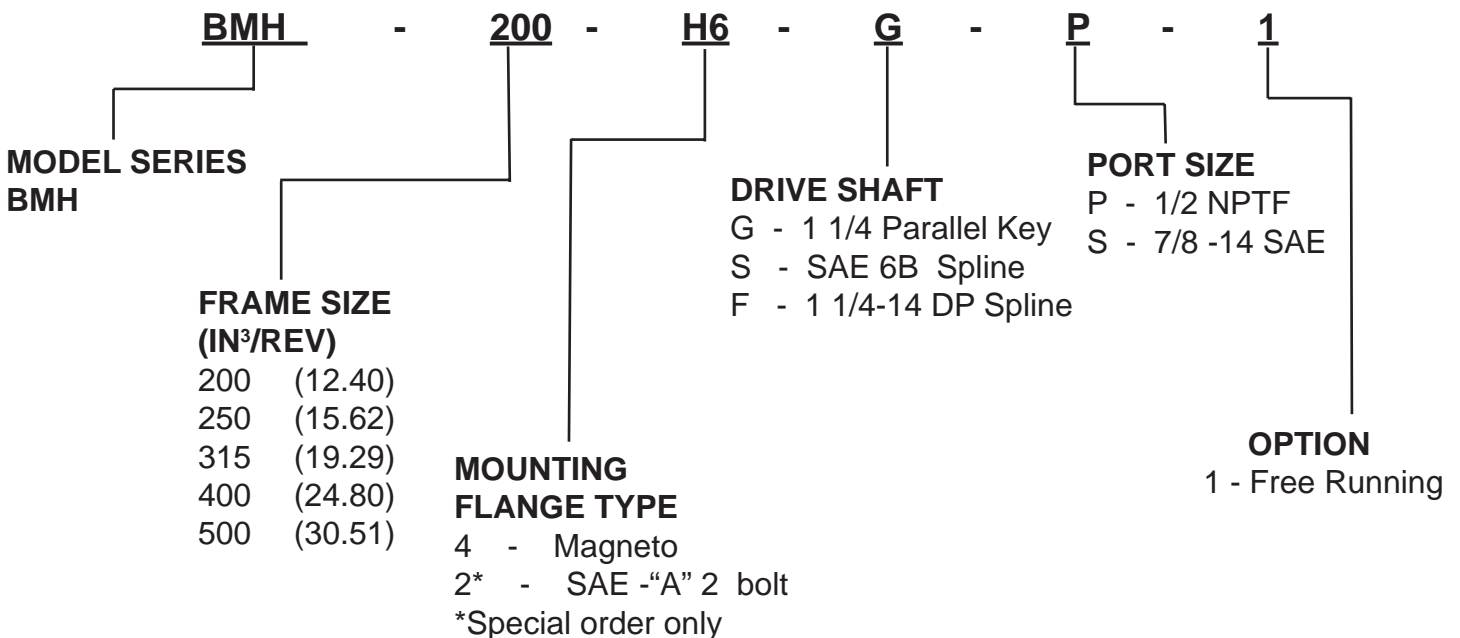

Additional flange and drive shaft options available please consult factory

BMH 200		203.2 Cm ³ /Rev 12.40 in ³ /Rev				Max Cont.	Max Int.
Pressure Mpa (psi)		3.5 (515)	7 (1030)	10.5 (1546)	14 (2060)	17.5 (2576)	20 (2950)
F L O W	LPM (GPM)	Torque Mn (in.Lbs) Speed Specification					
	5 (1.32)	98 (867)	194 (1717)	284 (2513)			
		25 rpm	25 rpm	22 rpm			
	10 (2.65)	101 (894)	204 (1805)	301 (2664)	391 (3460)	482 (4266)	
		43 rpm	41 rpm	36 rpm	29 rpm	14 rpm	
	20 (5.26)	99 (876)	201 (1779)	304 (2690)	402 (3558)	509 (4505)	576 (5098)
		100 rpm	97 rpm	93 rpm	85 rpm	69 rpm	56 rpm
	30 (7.90)	97 (858)	197 (1743)	300 (2655)	402 (3558)	510 (4513)	579 (5124)
		145 rpm	143 rpm	139 rpm	130 rpm	114 rpm	101 rpm
	40 (10.50)	90 (797)	190 (1681)	292 (2584)	399 (3531)	507 (4487)	578 (5115)
		200 rpm	200 rpm	200 rpm	188 rpm	168 rpm	153 rpm
	50 (13.15)	82 (726)	183 (1619)	284 (2513)	392 (3469)	500 (4425)	571 (5053)
		248 rpm	246 rpm	244 rpm	235 rpm	213 rpm	199 rpm
	60 (15.80)	73 (646)	174 (1540)	274 (2425)	384 (3398)	493 (4363)	563 (4982)
		292 rpm	290 rpm	287 rpm	279 rpm	260 rpm	244 rpm
	70 (18.40)	63 (557)	163 (1442)	264 (2336)	374 (3309)	481 (4256)	554 (4903)
	352 rpm	350 rpm	349 rpm	338 rpm	318 rpm	301 rpm	
75 (19.75)	59 (522)	157 (1389)	259 (2292)	366 (3239)	475 (4204)	547 (4841)	
	366 rpm	365 rpm	363 rpm	355 rpm	335 rpm	319 rpm	
Max Cont.	80 (21.05)	53 (469)	150 (1328)	253 (2239)	358 (3168)	466 (4124)	538 (4761)
		381 rpm	381 rpm	380 rpm	371 rpm	352 rpm	338 rpm
Max Int.	90 (23.68)	39 (345)	140 (1239)	241 (2133)	348 (3080)	456 (4036)	526 (4655)
		443 rpm	437 rpm	434 rpm	426 rpm	407 rpm	392 rpm

BMH 250		255.9 Cm ³ /Rev 15.62 in ³ /Rev				Max Cont.	Max Int.	
Pressure Mpa (psi)		3.5 (515)	7 (1030)	9 (1328)	12 (1766)	14.5 (2139)	17.5 (2576)	20 (2950)
F L O W	LPM (GPM)	Torque Mn (in.Lbs) Speed Specification						
	5 (1.32)	121 (1071)	246 (2177)	318 (2814)	398 (3522)			
		19 rpm	19 rpm	18 rpm	14 rpm			
	10 (2.65)	130 (1150)	258 (2283)	331 (2929)	425 (3761)	515 (4558)	595 (5266)	
		34 rpm	33 rpm	31 rpm	29 rpm	23 rpm	12 rpm	
	20 (5.26)	130 (1150)	258 (2283)	332 (2938)	432 (3823)	520 (4602)	621 (5496)	702 (6213)
		78 rpm	77 rpm	76 rpm	73 rpm	65 rpm	53 rpm	42 rpm
	30 (7.90)	122 (1080)	251 (2221)	327 (2894)	429 (3797)	520 (4602)	621 (5496)	700 (6195)
		115 rpm	113 rpm	111 rpm	105 rpm	96 rpm	84 rpm	75 rpm
	40 (10.50)	115 (1017)	240 (2124)	323 (2858)	422 (3735)	513 (4540)	616 (5452)	698 (6177)
		157 rpm	157 rpm	156 rpm	150 rpm	139 rpm	127 rpm	114 rpm
	50 (13.15)	105 (929)	232 (2053)	314 (2779)	411 (3637)	505 (4469)	606 (5363)	687 (6080)
		196 rpm	195 rpm	192 rpm	185 rpm	173 rpm	159 rpm	147 rpm
	60 (15.80)	94 (831)	220 (1947)	302 (2673)	401 (3549)	496 (4390)	596 (5275)	676 (5983)
		232 rpm	230 rpm	226 rpm	218 rpm	206 rpm	192 rpm	180 rpm
	70 (18.40)	81.4 (720)	209 (1850)	288 (2550)	389 (3442)	484 (4283)	582 (5150)	666 (5894)
	274 rpm	274 rpm	274 rpm	266 rpm	252 rpm	238 rpm	222 rpm	
75 (19.75)	72 (637)	203 (1796)	280 (2478)	381 (3372)	475 (4204)	574 (5080)	659 (5832)	
	290 rpm	289 rpm	287 rpm	279 rpm	266 rpm	251 rpm	236 rpm	
Max Cont.	80 (21.05)	66 (584)	194 (1717)	273 (2416)	371 (3283)	467 (4133)	566 (5009)	651 (5761)
		303 rpm	302 rpm	298 rpm	290 rpm	279 rpm	264 rpm	249 rpm
Max Int.	90 (23.68)	49 (433)	178 (1575)	256 (2266)	355 (3142)	453 (4009)	552 (4885)	634 (5611)
		348 rpm	347 rpm	345 rpm	337 rpm	325 rpm	309 rpm	292 rpm

BMH 315		316.1 Cm³/Rev 19.29 in³/Rev				Max Cont.	Max Int.		
Pressure Mpa (psi)		3.5 (515)	7.5 (1105)	10 (1470)	13.5 (1987)	15.5 (2286)	17.5 (2576)	20 (2950)	
F L O W	LPM (GPM)	Torque Mn (in.Lbs) Speed Specification							
	5 (1.32)	155 (1372)	325 (2876)						
		16 rpm	13 rpm						
	10 (2.65)	163 (1442)	342 (3026)	454 (4018)	556 (4921)				
		27 rpm	24 rpm	18 rpm	14 rpm				
	20 (5.26)	169 (1496)	349 (3089)	469 (4151)	582 (5150)	664 (5876)	733 (6487)	809 (7160)	
		63 rpm	61 rpm	55 rpm	48 rpm	40 rpm	32 rpm	19 rpm	
	30 (7.90)	165 (1460)	334 (3044)	470 (4159)	580 (5133)	669 (5921)	740 (6549)	824 (7292)	
		93 rpm	89 rpm	82 rpm	77 rpm	67 rpm	59 rpm	46 rpm	
	40 (10.50)	154 (1363)	337 (2982)	465 (4115)	577 (5106)	663 (5867)	737 (6522)	827 (7319)	
		126 rpm	126 rpm	119 rpm	111 rpm	99 rpm	88 rpm	73 rpm	
	50 (13.15)	141 (1248)	325 (2876)	455 (4027)	568 (5027)	656 (5806)	728 (6443)	824 (7292)	
		159 rpm	155 rpm	148 rpm	139 rpm	126 rpm	115 rpm	98 rpm	
	60 (15.80)	121 (1071)	312 (2761)	440 (3894)	555 (4912)	643 (5690)	715 (6328)	812 (7186)	
		187 rpm	186 rpm	179 rpm	169 rpm	154 rpm	143 rpm	124 rpm	
	70 (18.40)	103 (911)	298 (2637)	425 (3761)	541 (4788)	631 (5584)	703 (6221)	800 (7080)	
	222 rpm	222 rpm	215 rpm	205 rpm	187 rpm	176 rpm	157 rpm		
75 (19.75)	94 (831)	287 (2540)	417 (3690)	529 (4682)	623 (5514)	696 (6160)	792 (7009)		
	236 rpm	233 rpm	224 rpm	215 rpm	196 rpm	184 rpm	166 rpm		
Max Cont.	80 (21.05)	82 (726)	277 (2451)	406 (3593)	518 (4584)	611 (5407)	688 (6089)	784 (6938)	
		246 rpm	244 rpm	236 rpm	228 rpm	210 rpm	197 rpm	174 rpm	
Max Int.	90 (23.68)	62 (549)	256 (2266)	386 (3416)	496 (4390)	593 (5248)	669 (5921)	767 (6788)	
		282 rpm	280 rpm	275 rpm	266 rpm	248 rpm	234 rpm	209 rpm	

BMH 400		406.4 Cm³/Rev 24.80 in³/Rev				Max Cont.	Max Int.	
Pressure Mpa (psi)		3.5 (515)	6 (885)	10.5 (1546)	12.5 (1840)	15.5 (2286)	19 (2802)	
F L O W	LPM (GPM)	Torque Mn (in.Lbs) Speed Specification						
	5 (1.32)	196 (1735)	348 (3080)	516 (4566)				
		13 rpm	13 rpm	10 rpm				
	10 (2.65)	205 (1814)	363 (3212)	546 (4832)	702 (6213)	859 (7602)		
		22 rpm	21 rpm	21 rpm	17 rpm	11 rpm		
	20 (5.26)	209 (1850)	366 (3239)	543 (4805)	708 (6266)	874 (7735)	988 (8744)	
		50 rpm	49 rpm	46 rpm	41 rpm	36 rpm	31 rpm	
	30 (7.90)	201 (1779)	357 (3159)	542 (4797)	706 (6248)	864 (7646)	984 (8708)	
		73 rpm	72 rpm	70 rpm	63 rpm	56 rpm	51 rpm	
	40 (10.50)	195 (1726)	346 (3062)	532 (4708)	701 (6204)	858 (7593)	973 (8611)	
		99 rpm	98 rpm	96 rpm	86 rpm	77 rpm	71 rpm	
	50 (13.15)	173 (1531)	332 (2938)	518 (4584)	687 (6080)	848 (7504)	958 (8478)	
		123 rpm	122 rpm	118 rpm	107 rpm	97 rpm	90 rpm	
	60 (15.80)	154 (1363)	319 (2823)	501 (4434)	668 (5912)	833 (7372)	944 (8354)	
		146 rpm	144 rpm	141 rpm	128 rpm	115 rpm	106 rpm	
	70 (18.40)	138 (1221)	305 (2699)	480 (4248)	649 (5744)	814 (7204)	925 (8186)	
	174 rpm	173 rpm	169 rpm	156 rpm	141 rpm	130 rpm		
75 (19.75)	128 (1133)	294 (2602)	466 (4124)	637 (5637)	802 (7098)	911 (8062)		
	183 rpm	181 rpm	177 rpm	163 rpm	149 rpm	138 rpm		
Max Cont.	80 (21.05)	113 (1000)	277 (2451)	451 (3991)	621 (5496)	786 (6956)	899 (7956)	
		192 rpm	191 rpm	188 rpm	174 rpm	158 rpm	144 rpm	
Max Int.	90 (23.68)	90 (796)	256 (2266)	433 (3832)	595 (5266)	767 (6788)	881 (7797)	
		220 rpm	220 rpm	215 rpm	202 rpm	183 rpm	165 rpm	

BMH 500		500 Cm³/Rev 30.51 in³/Rev				Max Cont.	Max Int.
Pressure Mpa (psi)		2.5 (368)	5 (738)	8.5 (1254)	10 (1470)	12.5 (1840)	16 (2355)
F L O W	LPM (GPM)	Torque Mn (in.Lbs) Speed Specification					
	5 (1.32)	165 (1460)	317 (2805)	516 (4567)			
		11 rpm	11 rpm	8 rpm			
	10 (2.65)	178 (1575)	335 (2965)	555 (4912)	669 (5921)	791 (7000)	969 (8576)
		20 rpm	19 rpm	17 rpm	15 rpm	13 rpm	9 rpm
	20 (5.26)	177 (1566)	331 (2929)	559 (4947)	673 (5956)	799 (6894)	988 (8744)
		42 rpm	42 rpm	41 rpm	38 rpm	36 rpm	29 rpm
	30 (7.90)	172 (1522)	320 (2832)	553 (4894)	663 (5867)	792 (7009)	983 (8699)
		64 rpm	63 rpm	61 rpm	57 rpm	53 rpm	47 rpm
	40 (10.50)	163 (1443)	309 (2735)	541 (4788)	654 (5788)	783 (6930)	971 (8593)
		85 rpm	85 rpm	83 rpm	79 rpm	75 rpm	67 rpm
	50 (13.15)	146 (1292)	296 (2120)	523 (4628)	635 (5620)	768 (6797)	954 (8443)
		103 rpm	103 rpm	103 rpm	97 rpm	93 rpm	85 rpm
	60 (15.80)	121 (1071)	275 (2434)	502 (4443)	614 (5434)	747 (6611)	934 (8266)
		124 rpm	124 rpm	123 rpm	117 rpm	113 rpm	103 rpm
	70 (18.40)	97 (858)	256 (2266)	482 (4266)	597 (5283)	729 (6452)	917 (8115)
	148 rpm	148 rpm	148 rpm	140 rpm	134 rpm	122 rpm	
75 (19.75)	79 (699)	240 (2124)	469 (4151)	582 (5151)	714 (6319)	902 (7983)	
	155 rpm	155 rpm	155 rpm	152 rpm	144 rpm	130 rpm	
Max Cont.	80 (21.05)	60 (531)	226 (2000)	453 (4009)	570 (5044)	701 (6204)	884 (7823)
		166 rpm	166 rpm	166 rpm	159 rpm	153 rpm	139 rpm
Max Int.	90 (23.68)	34 (301)	201 (1779)	421 (3726)	550 (4868)	673 (5956)	869 (7691)
		166 rpm	165 rpm	164 rpm	157 rpm	156 rpm	155 rpm

MODEL BMH TECHNICAL DATA

SHAFT SEAL RATED PRESSURE

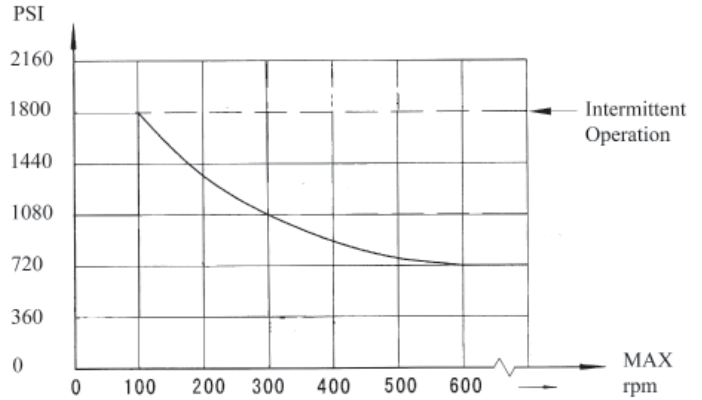
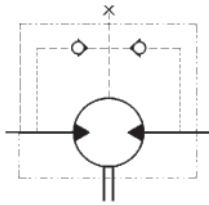

CASE DRAIN

In applications without a motor drain line, the pressure exerted on the shaft seal is marginally in excess of the return line pressure. When the drain line is used the pressure exerted on the shaft seal is equal to the return line pressure.

SHAFT ROTATION DIRECTION

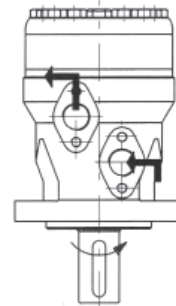

RADIAL FORCES

Status of the shaft's radial force

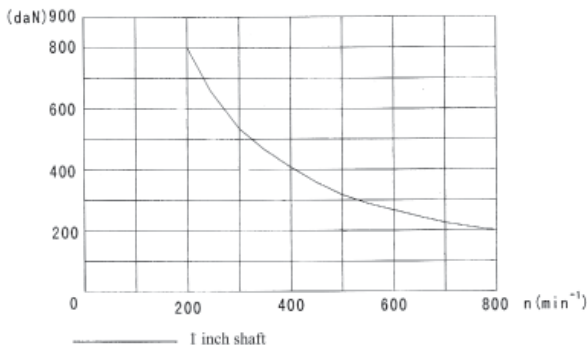

$$F_r = \frac{800 \cdot 2500}{n \cdot 95 + 1} \text{ daN}$$

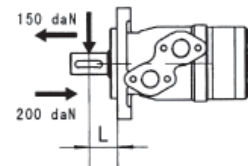

F_r = Radial Force (daN)
 L = Distance (mm)
 n = Speed (rpm)

Rhomb-flange $L=30\text{mm}$
 Square-flange $L=24\text{mm}$